

ITEM	PART NUMBER	DESCRIPTION	QTY
1	EXPANDING MECHANISM ASSEMBLY		
A	E02-04089-006	HUB	1
B	E02-01616-07	NON MAGNETIC PISTON	2
C	E02-01616-08	CLEVIS BRACKET	2
D	E02-01616-09	THRUST WASHER	4
E	E02-01616-10	BEARING	22
F	E02-01616-11	PIN	2
G	E02-01616-12	RETAINING RING	2
H*	E02-01618-01	SHOE	2
I	E02-01619-01	LINK	2
J	E02-01619-02	SINGLE LINK	4
K	E02-01619-03	STOP PAD	2
L	E02-01619-04	STOP SHIM	2
M	E02-01619-05	HINGE PIN	2
N	E02-01619-06	PIN	2
O	E02-01619-07	LONG PIN	2
P*	E02-01619-08	HINGE PIN	2
Q	E02-01620-01	SETUP LINK	2
R	E02-01620-02	ROD END	2
S	E02-01620-06	DIAPHRAGM ACCUMULATOR	2
T	E02-00679-01	CAP MOUNTING BLOCK	2
T~	E02-00679-02	CAP MOUNTING BLOCK	2

NAME	REV	DATE	DESCRIPTION
CLEU	XA	03/12/97	EXPERIMENTAL

~ USED ON ALL ORDERS BUT 04-089

* SEE HARDWARE BILL OF MATERIAL

HARDWARE BILL OF MATERIAL			
ITEM	PART NUMBER/DESCRIPTION		QTY
1A	FW CL 14	CARR-LANE FLATWASHER	4
1A	SB 1/4 X 3/4	1/4-20 X .75" LG. SHOULDER BOLT	4
1T	SHCS 1/4-20 X .75	1/4-20 X .75" LG. SHCS.	4

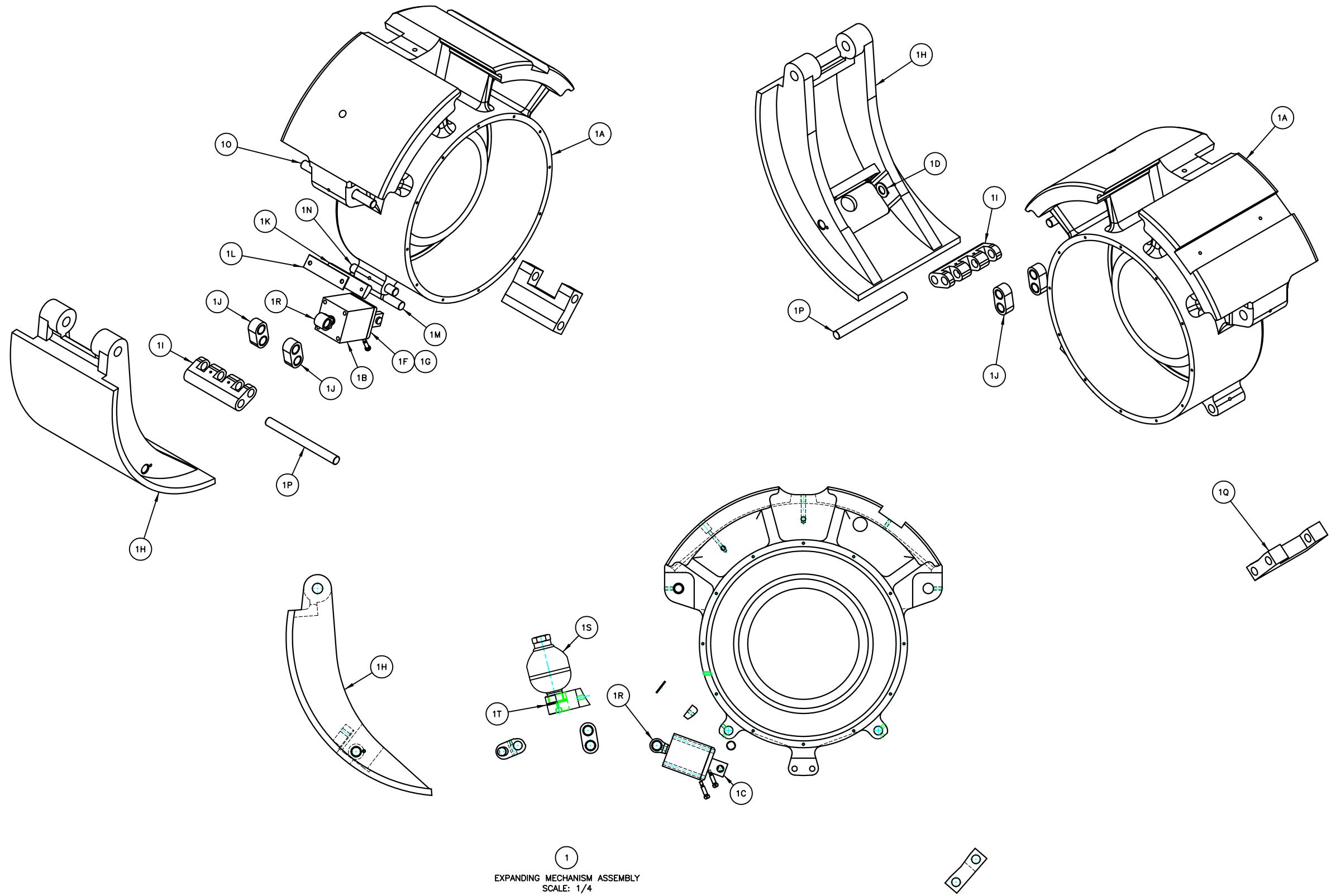

1
EXPANDING MECHANISM ASSEMBLY
SCALE: 1/4

<p>TOLERANCES UNLESS OTHERWISE SPECIFIED</p> <p>.XX = ±.03 .XXX = ±.005 .XXXX = ±.0005 ANGLES: XX.X° = ±.5°</p> <p>CONFIDENTIAL THE CONTENTS OF THIS DRAWING ARE PROPRIETARY TO MACHINE CONCEPTS AND MUST NOT BE REPRODUCED OR COPIED. THIS DRAWING MUST BE RETURNED UPON REQUEST.</p>	<p>THIRD ANGLE PROJECTION</p>	<p>Machine Concepts Inc. 2167 St. Rt. 66 P.O. Box 127 Minster, Ohio 45865 (419)628-3498 FAX 2794</p>	<p>DATE: 05/25/04</p>	<p>SECTION: MANDREL SEGMENT ASSEMBLY</p>	<p>SHEET: 1 of 1</p>	<p>REV: A</p>
	<p>DRAWN: RMA</p>		<p>MANAGER: RMA</p>	<p>DESCRIPTION: EXPAND/COLLAPSE MECHANISM</p>	<p>DRAWING NO.: E02-04089-002</p>	
	<p>SCALE: 1/4</p>		<p>DATE: 05/25/04</p>	<p>SECTION: MANDREL SEGMENT ASSEMBLY</p>	<p>SHEET: 1 of 1</p>	<p>REV: A</p>
	<p>SCALE: 1/4</p>		<p>DATE: 05/25/04</p>	<p>SECTION: MANDREL SEGMENT ASSEMBLY</p>	<p>SHEET: 1 of 1</p>	<p>REV: A</p>

This document was created with Win2PDF available at <http://www.win2pdf.com>.
The unregistered version of Win2PDF is for evaluation or non-commercial use only.